

# PALOMINO CHAIR



**schiaavello**

# IVAN WOODS

Schiavello and Ivan Woods have a long history. Our collaborative design process, which has evolved over many years, has yielded distinctive collections such as the Kayt and Toro collections.

Ivan enriches his designs' emotional qualities through fine detailing, influenced by a strong architectural sensibility and carefully considered geometry. The unique combination of individual and robust personalities in his products results in a unique outcome that has lent his products to a diverse range of scenarios.

Ivan grew up in Australia and studied interior architecture in Perth. Having designed interiors and products for over 30 years, he has created work for the Langham and Marriot hotels as well as international projects spanning the UK, US, Germany and Italy.

---







Palomino caters to the changing workplace and the growing trend for furniture that bridges the gap between the home and office.

Office environments and working philosophies will continue to diversify. The growing desire for agile working has seen a change in the attitude towards the office, as more and more people are seeking flexible working alternatives, often preferring to work from home on occasion. Transitional furniture will have a strong presence in the workplace as people seek new ways to create comfort and a sense of

connection to the spaces they occupy daily. A lounge chair at heart, the Palomino Chair creates inviting spaces and evokes a sense of comfort.

At the office, Palomino is well suited to breakout areas, training rooms, meeting rooms and boardrooms. At home, a calming addition to home offices, living and dining spaces. Inspiring creativity while supporting our various requirements, the Palomino Chair features a diverse range of bases and upholstery finishes.





# Specifications

## Timber base

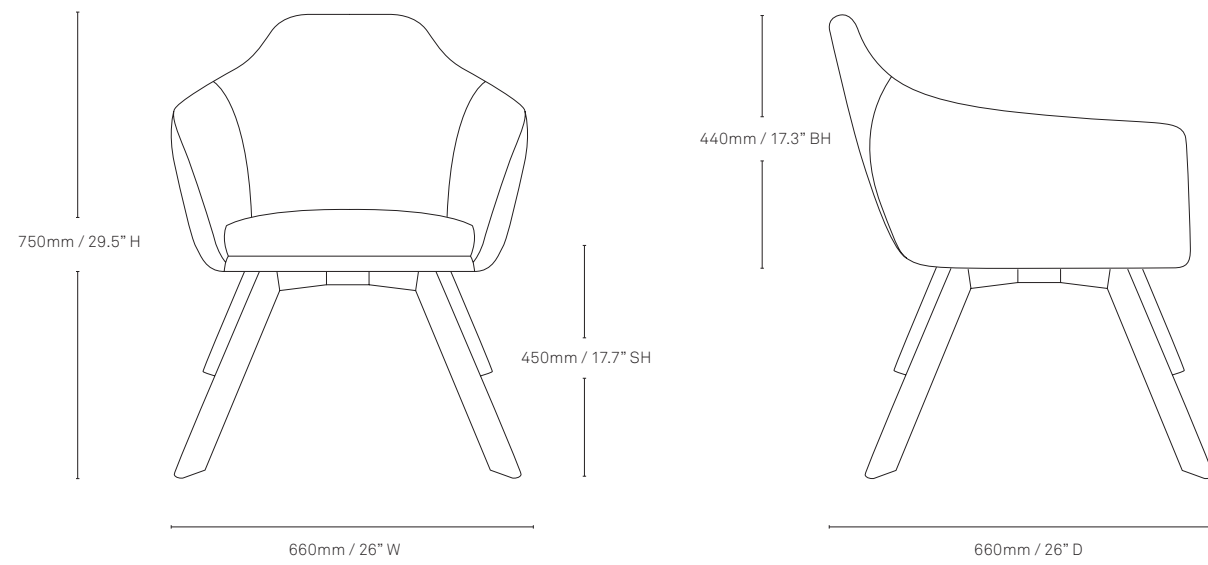

## 4-star on castors

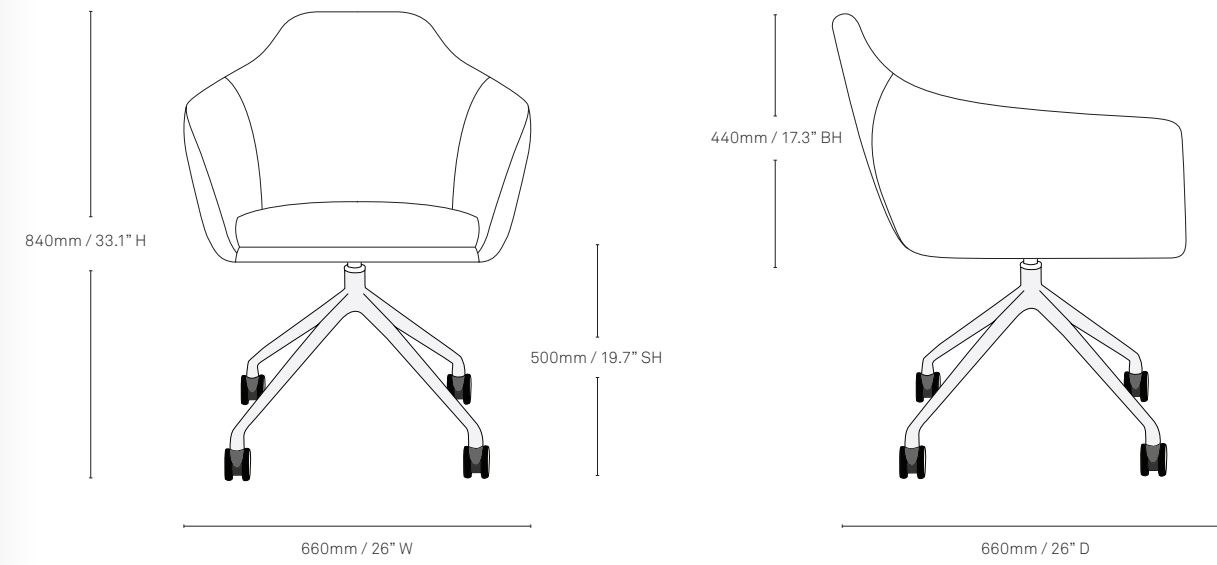

## 4-star

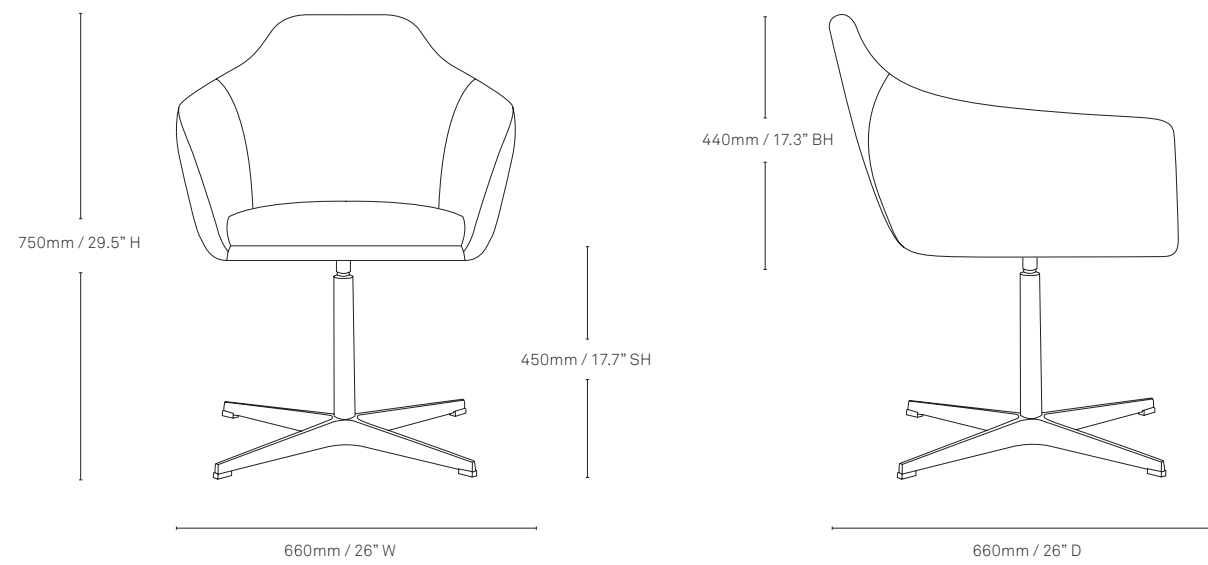

## 4 legs

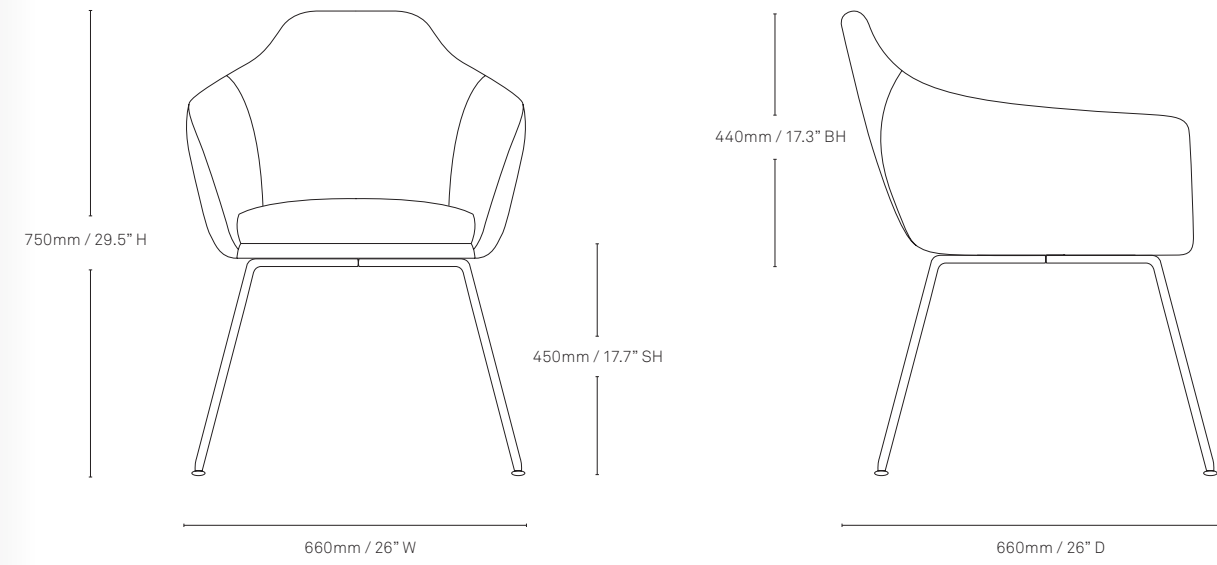

5-star on castors

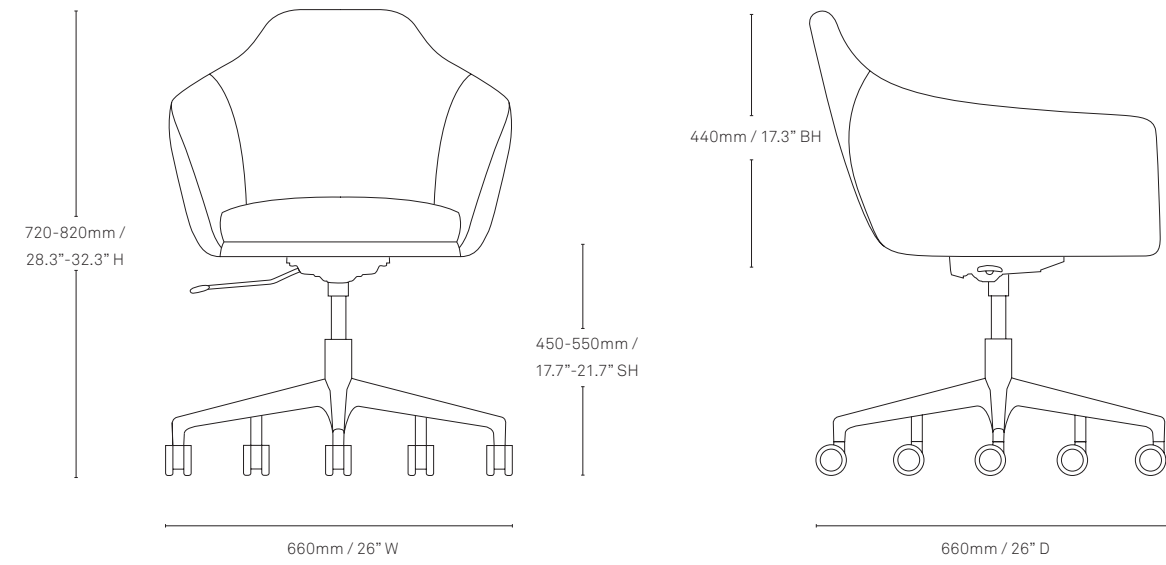

Sled base

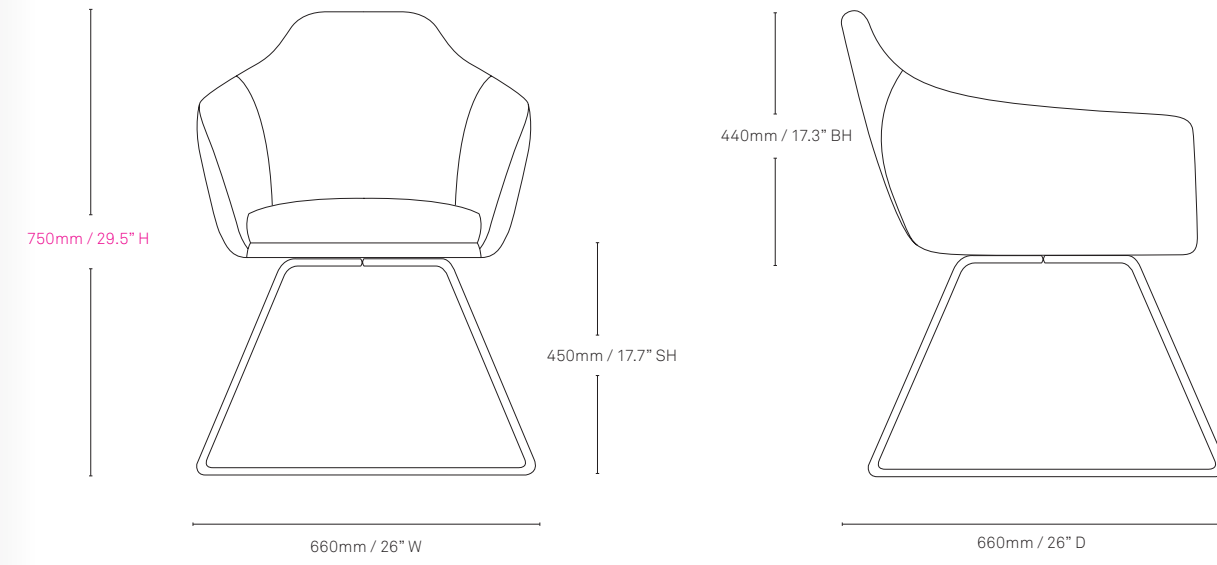

Glides

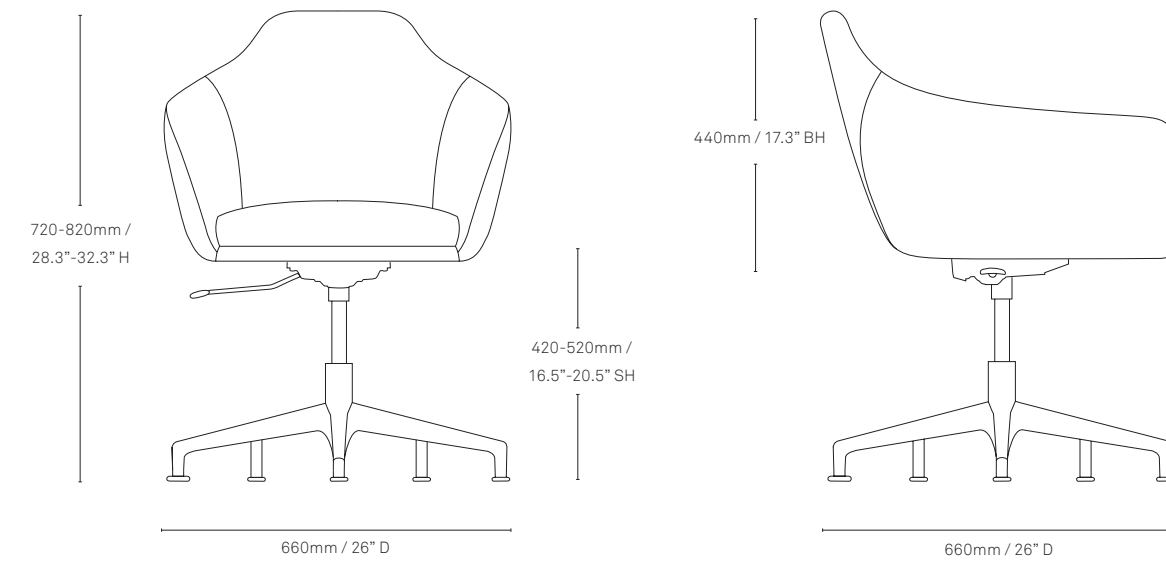

# ColourLab

Schiavello's innovative ColourLab brings a considered and cohesive palette of finishes to working and living spaces. Curated by Giulio Ridolfo and developed by Schiavello, the palette beautifully balances colour, texture and layering across a variety of materials.

**CATEGORY 1**  
Edge, Focus  
& Messenger

## FABRIC

### EDGE / Category 1

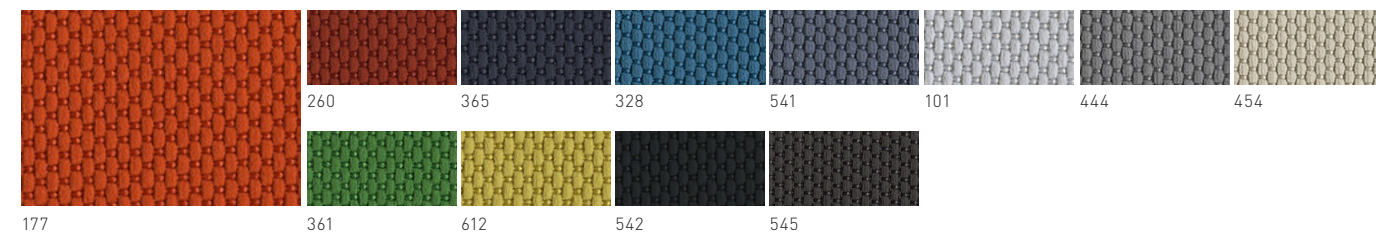

### FOCUS / Category 1

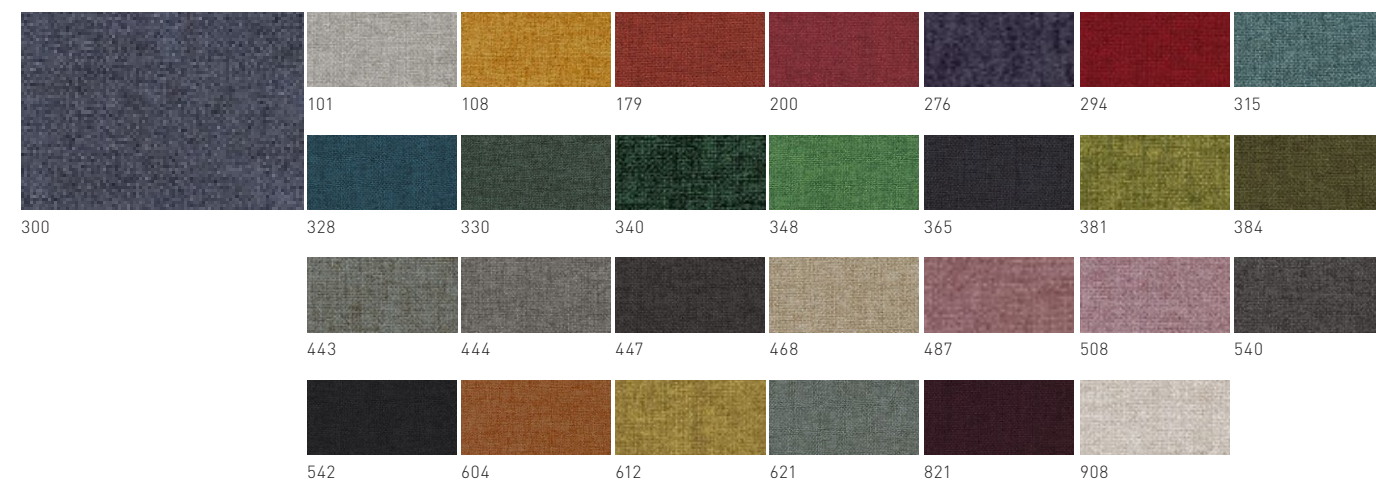

### MESSENGER / Category 1

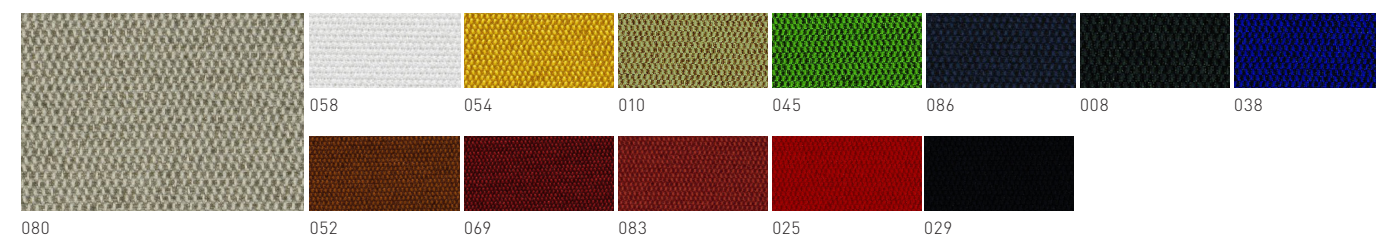





CATEGORY 2  
Metric

CATEGORY 3  
Atlas & Revive 1

METRIC / Category 2



ATLAS / Category 3

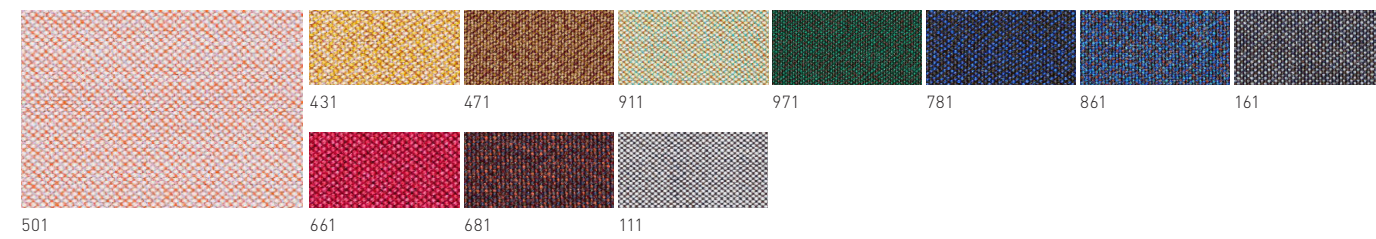

REVIVE 1 / Category 3



CATEGORY 4  
Glow, Recheck,  
Remix 3 & Rime

GLOW / Category 4

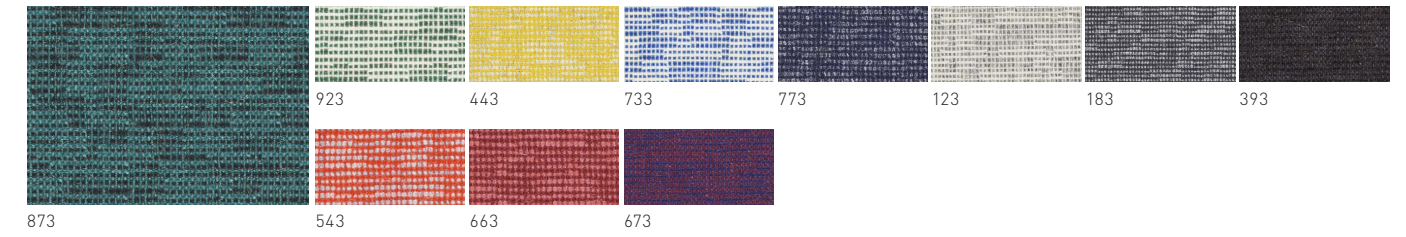

RECHECK / Category 4

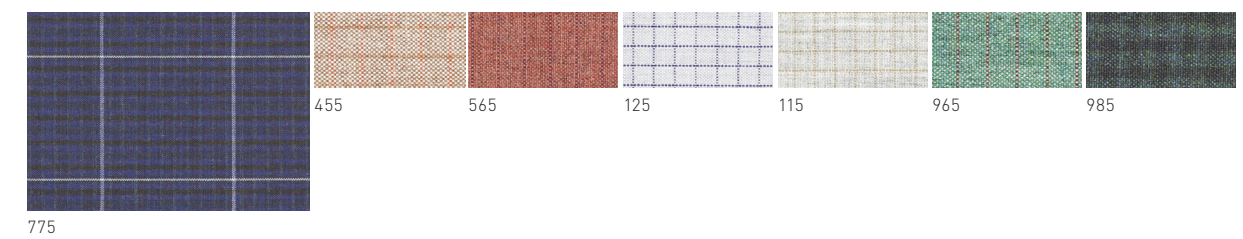

REMIX 3 / Category 4

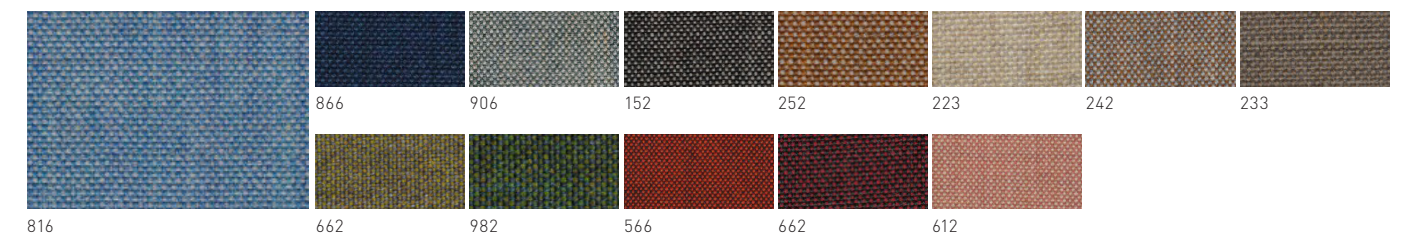

RIME / Category 4

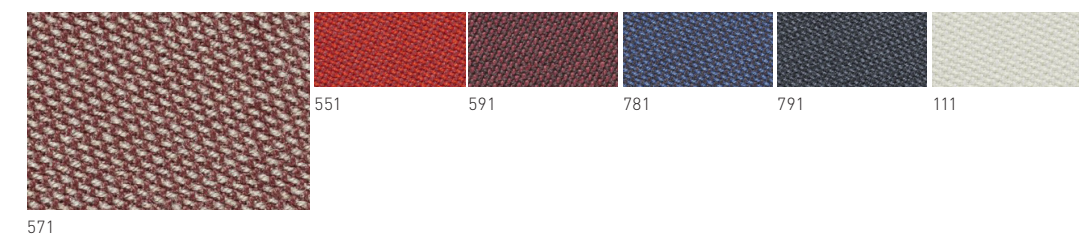



**CATEGORY 5**  
Steelcut Trio 3  
& Tonica 2

**STEELCUT TRIO 3 / Category 5**



**TONICA 2 / Category 5**

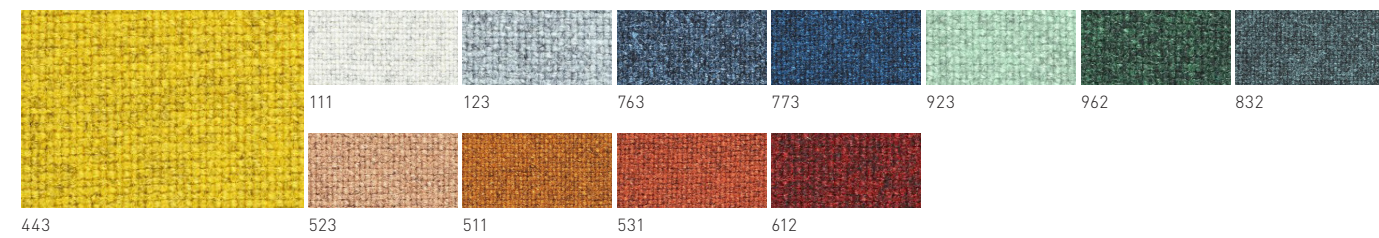

**HEALTHCARE  
FABRIC**

**SILK / Category 1.5**

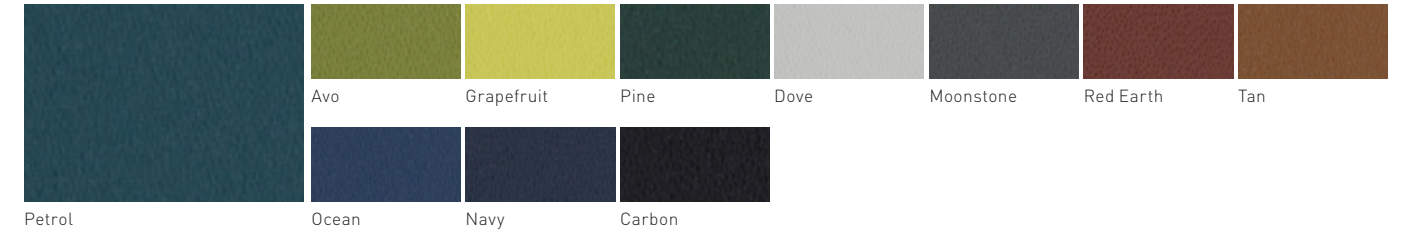

**RAVE / Category 2**

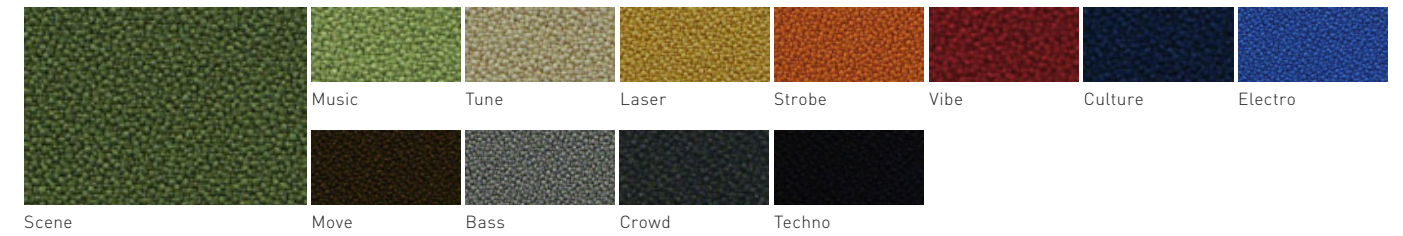

**TRIESTE / Category 2.5**

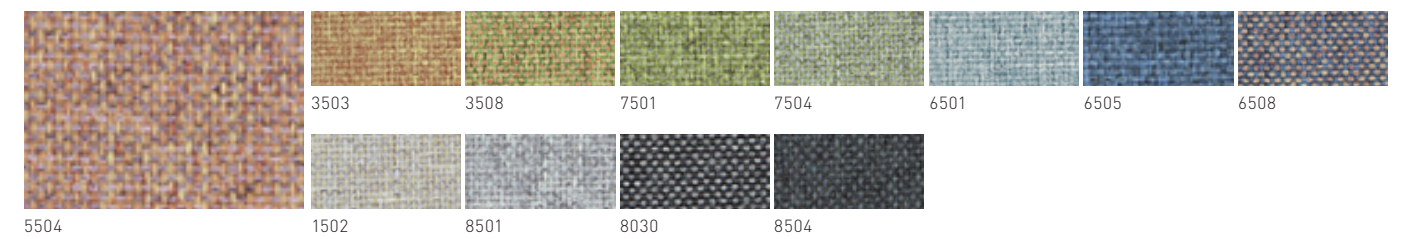

**CATEGORY 1.5**  
Silk

**CATEGORY 2**  
Rave

**CATEGORY 2**  
Trieste



LEATHER

**METADOR / Category 2**



**CATEGORY 2**  
Metador

**CATEGORY 3**  
Medici

**CATEGORY 4**  
Heirloom

**MEDICI / Category 3**



**HEIRLOOM / Category 4**



# Legs

## FINISH

- Satin
- ‡ Texture

### METAL POWDER COAT

#### METAL POWDER COAT / Category 1



#### METAL POWDER COAT / Category 2



#### METAL POWDER COAT / Category 3

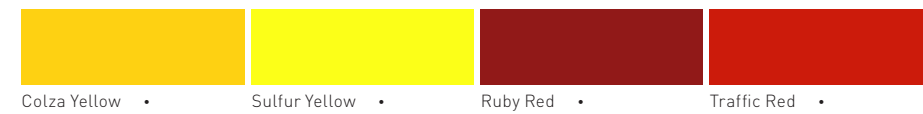

### TIMBER NATURAL

#### Species



#### Applied Finishes

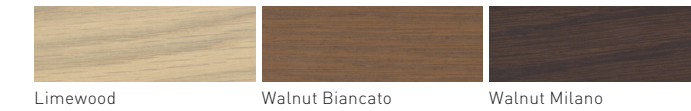

### TIMBER PAINT



### TIMBER WASH





## Ecology and sustainability

Schiavello's most important commitment to sustainability is the company-wide Environmental Management System under ISO 14001. The environmental design principles realised means we design for the environment, focusing on efficient energy use and minimum emissions, longevity and durability, re-use and recycling of our products.

Our principles of ME WE (Materials, Energy, Waste Emissions) give us a simple way to think about how our operations impact the environment.

Printed on an Australian made paper stock that is PEFC Certified and made from elemental chlorine-free bleached pulp sourced from sustainably managed forests and non-controversial sources. It is manufactured by an ISO 14001 certified mill using renewable energy sources.



FS 604920

EMS 604919

## About Schiavello

Schiavello is a multi-disciplinary company dedicated to developing intelligent, inspiring, ecological and resilient solutions for the office, the home and public spaces.

Schiavello's concepts and products are developed in Australia by applying a design process that brings together the company's core design principles and engineering with the creativity of local and international designers.

The Schiavello head office and world-class manufacturing facilities are integral to our continually developing rich tapestry of knowledge. This knowledge ultimately assists us in informing the right solutions and tools for each organisation's needs and people, allowing us to consistently achieve our philosophy that 'Anything is possible'.

To find a Schiavello showroom or partner in your area, please visit [schiavellofurniture.com/find-us](https://www.schiavellofurniture.com/find-us)

All intellectual property rights and copyrights are reserved. Nothing contained in this brochure may be reproduced without written permission. Schiavello Group Pty Ltd reserves the right to change any or all details without prior notice. All dimensions stated within this document are nominal and/or approximate only and subject to variation.

SCHC43.0D-C