

Focus Quiet Room



A symbol for concentration¹

Focus Quiet Work Room is a precision engineered room, providing a place of uninterrupted focus and privacy within the modern workplace through market leading acoustic performance.

schiaavello

The Knowledge collection

Schiavello's Knowledge collection is comprised of cutting-edge products that are based on extensive research conducted by our Schiavello Design Studio and People and Culture Consulting teams. Led by strategic research into how businesses and employees function, these products help achieve goals and solve problems within the workspace furniture industry.



Contents

Designer

1 — 2

Focus Quiet Room collection

3

Quality & safety assurance

15 — 16

Best practice accessibility

19 — 20

Features & accessories

25 — 26

Specifications

29 — 34

How to Select Finishes

35

SCHIAVELLO DESIGN STUDIO

The Schiavello Design Studio is made up of a number of multi-disciplinary designers and engineers with expertise in industrial design, interior design and product engineering. Supported by an array of trade-based professionals, the technically focused team brings a diverse expertise to new and evolved product development.

Maintaining thoughtful, innovative and research-driven outlooks on design trends, the Schiavello Design Studio has been the driving force behind a number of the company's most successful designs. Some of the team's most notable concepts include Krossi in 2013 – the first and only Australian made and designed sit/stand desk – and the pioneering Climate workplace system in 2010, which is still one of the most malleable products of its kind. In addition, the studio continues to develop Schiavello's furniture offering, catering to changing typology trends, business and people needs and technology requirements, while maintaining product quality, longevity, effortless visual appeal and environmental sustainability.



Introducing Focus Quiet Room

Mobilise your office

Focus Quiet Room is a precision engineered booth, providing a place of uninterrupted focus and privacy within your office space.

Powered, ventilated and equipped to function comparably with any architectural structure, yet mobile in nature for ease of future reconfiguration or relocation.

Alongside globally recognised safety certification bodies UL & BIFMA, Schiavello regards the Focus Quiet Room range as powered furniture.



Leading acoustic performance

With an insulated ceiling, walls and thick 10.38mm laminated glass, paired with an automatic drop seal at the base of the door, Focus Quiet Room achieves an exemplary acoustic rating of Dw32. Allowing minimal opportunity for sound to intrude or escape, this beautiful piece of considered engineering results in a room where employees can go to focus with minimum disruption.



Improve productivity

Distracting and intrusive noise can lead to poor concentration and, as a result, is a costly problem for businesses today. Research suggests that office workers lose over an hour per day due to uncontrolled interruptions. Focus Quiet Rooms create a place of solace from the bustling surrounding environment – a place where concentration can occur without distraction.



From a phone booth to a meeting room

Focus Quiet Rooms are available in various sizes to create the right place for an array of tasks or needs. The classic **Phone Room** is designed to fit a work shelf and stool to create a low footprint space for private calls.

The mid-size **Work Room**, ideal for video conference calls, longer phone calls or high concentration solo work, can accommodate a generously proportioned lounge chair and a side table, or a task chair and 1270mm (50") wide workpoint.

For added functionality with a similar footprint – 270mm (10.6") deeper – the **Duo Work Room** creates a space for small meetings of two, designed for optimal video conferencing. Duo in name and purpose, this enhanced Work Room also provides ample space for wheelchair accessibility.

Meanwhile, in the **Meeting Room** – the most generous of Focus Quiet Rooms – a combination of furniture can be used, including a sofa and executive desk for a private office, or a table with chairs to create a confidential meeting room.



Meeting Room



Duo Work Room



Work Room



Phone Room

Complete comfort

Focus Quiet Rooms come with integrated, motion-sensor lighting and ventilation services in the ceiling with the option to add wall mounted switches for manual control, such as dimmable lighting. Quiet and seamless, the integrated fans circulate air flow maintaining office temperature inside of the room.



Quality & safety assured

The Focus Quiet Room range (Meeting Room, Duo Work Room, Work Room and Phone Booth) has been engineered to meet *Global Building and Furniture Standards across stability, ventilation, lighting; DDA compliance (AS1428)* and *fire safety compliance*. The following certification has been achieved;

UL (Underwriters Laboratories) Certification

Under standard UL 962. Certificate download available online. Founded in 1894, UL is a global safety certification company, headquartered in Northbrook, Illinois.

Special Seismic Certification

Qualified in accordance with International Building Code (IBC) 2018 and California Building Code (CBC) 2019.

Seismic certification ensures components will withstand and operate after an event such as an earthquake.

*Please ensure relevant certifying bodies are consulted prior to specification and purchase.



Focus for all abilities

A step-free floor and engineered door handle design offer increased accessibility across the entire collection. The Meeting and Duo Work Room's generous proportions enhance it even further, providing ample opening and circulation space, to deliver a dedicated private space for people of all abilities.



Best practice accessibility

Specific features that enhance the Focus Quiet Room collection's accessibility, includes:

1. Door handle placement, height within reach
2. Handle operation, minimal force/strength to open
3. No-step floor, minimal change in level
4. Door opening, ample width (full width opening 906mm/34.2")
5. Doorway access, ample circulation space within Duo Work and Meeting Rooms
6. Interior power unit and switches, height position within reach

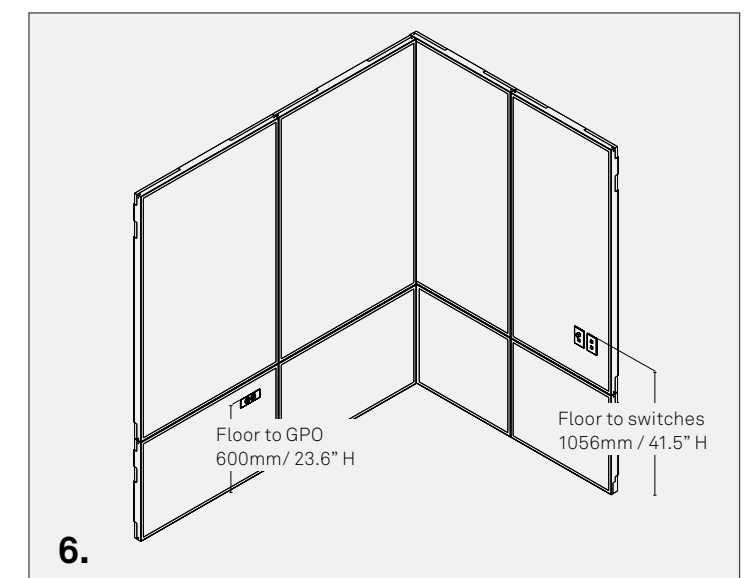
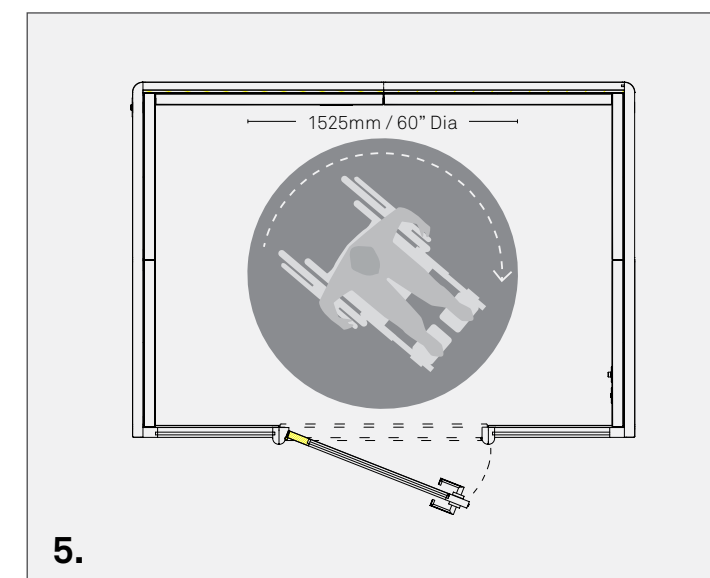
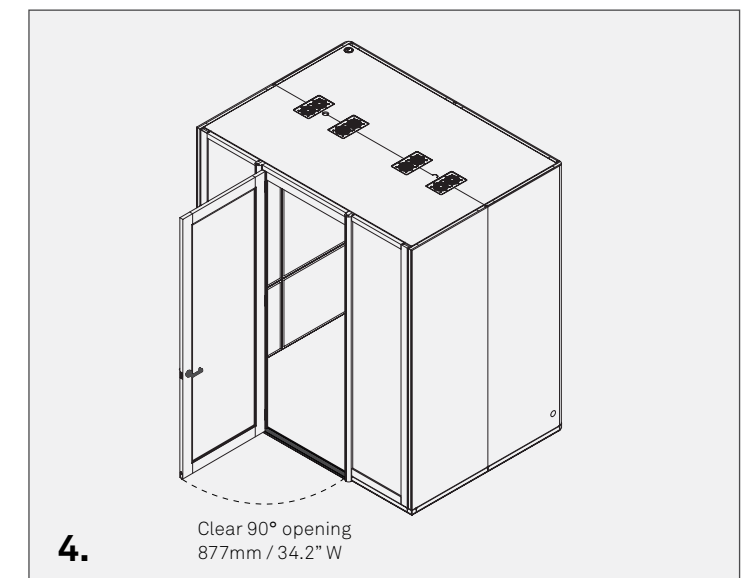
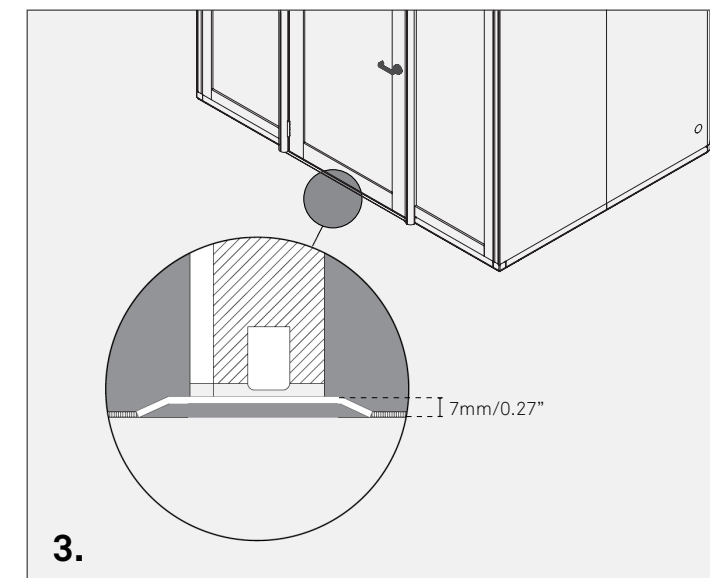
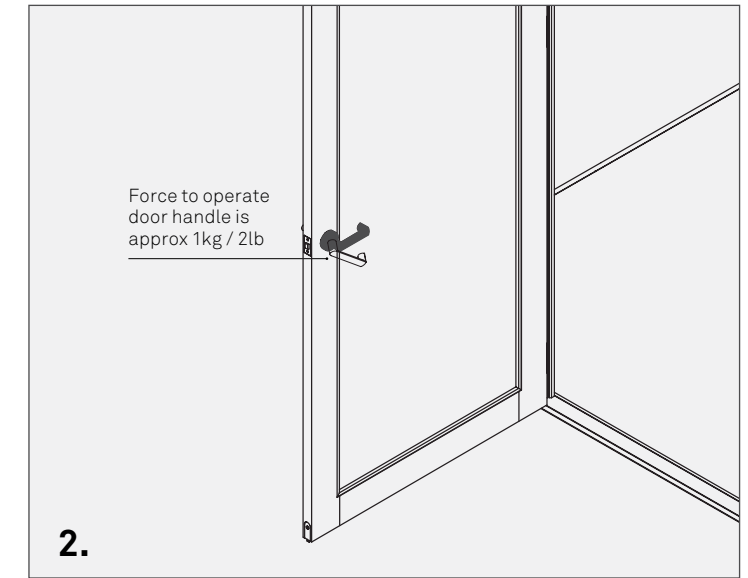
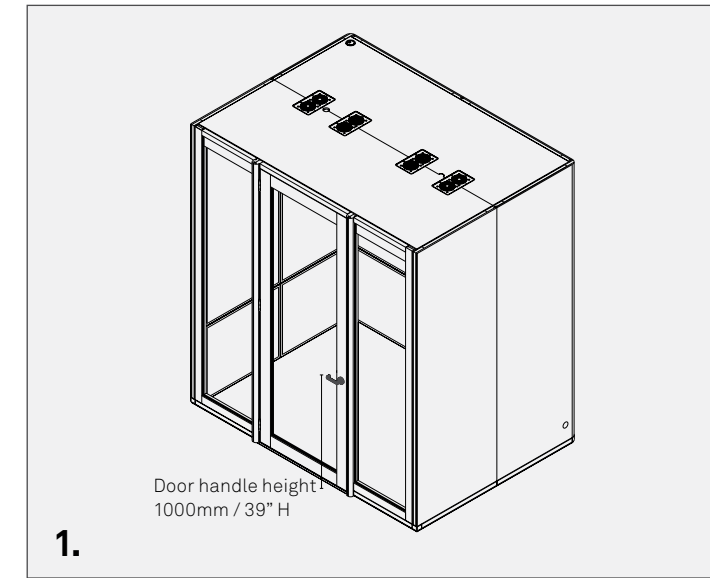

Build your way

Create a bespoke Focus Quiet Room that will work seamlessly with your interior palette. Each room comes highly customisable with a wide range of fabric and leather upholstery options as well as hard finishes such as laminate or veneer, via Schiavello's ColourLab palette. Create the booth you want with a wide range of shapes, add-ons and functions. The units can even be reconfigured after years of use.



A true companion to the modern workspace

Focus Quiet Room is able to come integrated with a range of customisable technology functions, including power, HDMI, USB and mounting for screens. They can also be customised with shelves, workstations and accessories such as whiteboards and pinboards.



Features & accessories

With integrated power and a selection of panel finishes as standard, the built-in benefits of Focus Quiet Room can be amplified through our range of functional and tech-enhanced accessories.

Features

Fabric wrapped wall tile



Fabric wrapped ceiling tile



Integrated power outlet tile

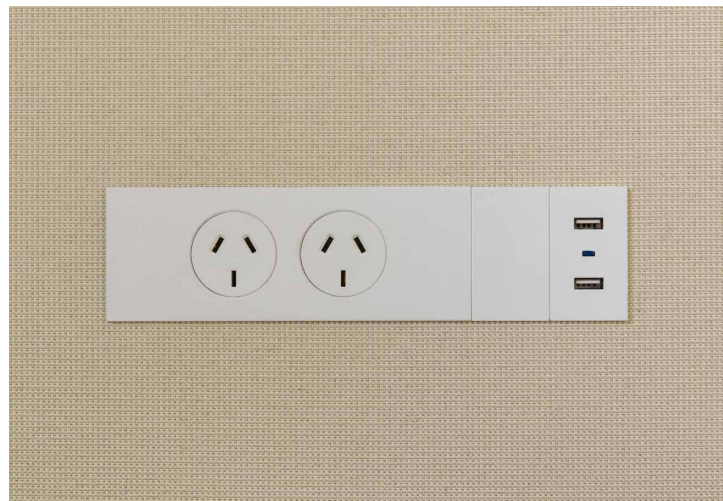

Perforated metal wall tile

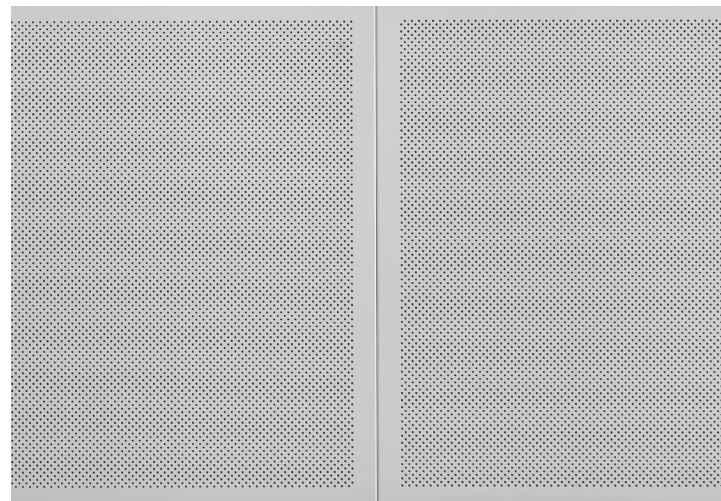

Accessories

AV

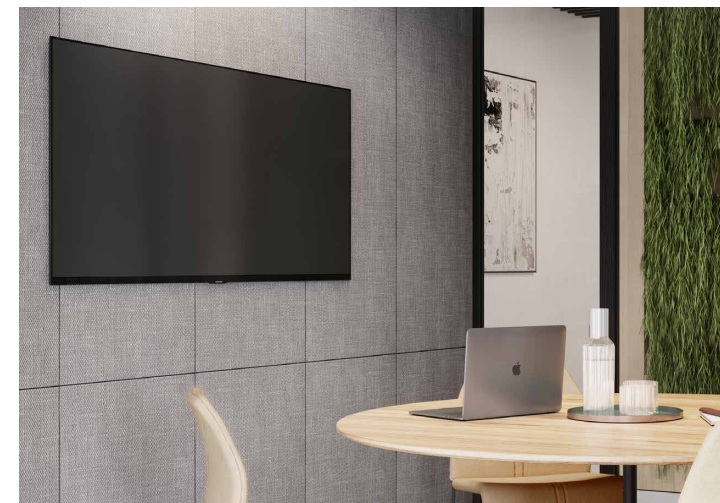

Ottoman



Whiteboard

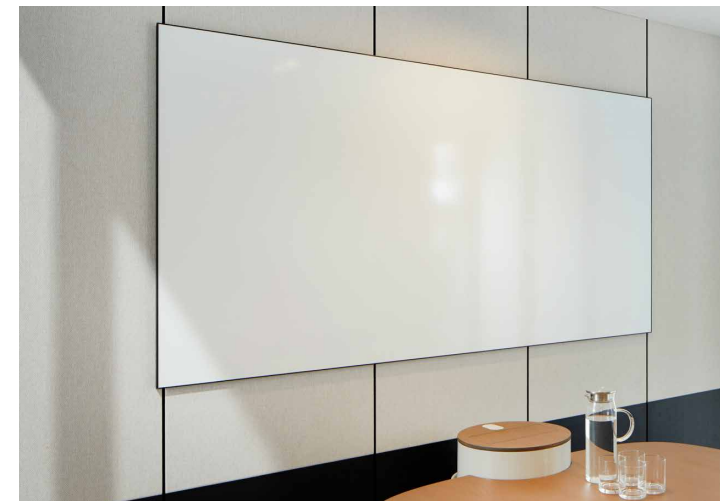



Specifications

Specifications

Phone Room

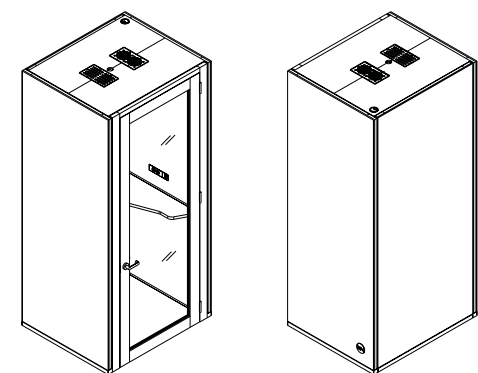

Room back: acoustic panel

Standard height is:
2550mm

Phone Room rear wall available in
a solid or glazed panel.

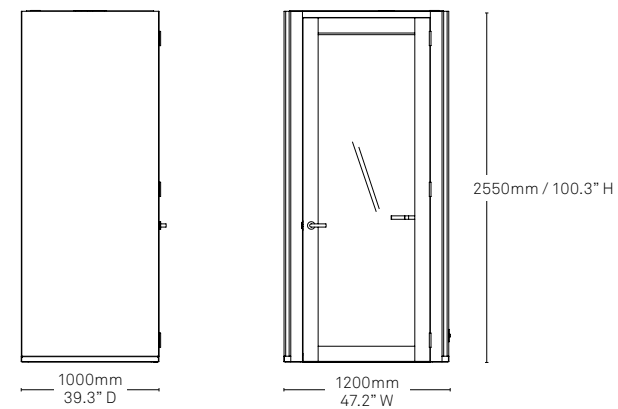

Work Room

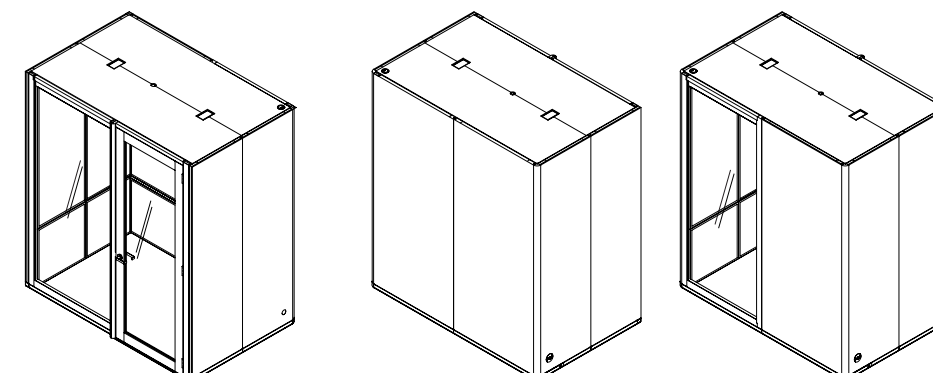

Front: offset door panel

Room back: acoustic panel

Room back: glazed panel

Standard height is:
2550mm

Work Room rear wall available in
a solid panel or
2 x glazed panels

Front wall available in
1 or 2 x glazed panels.

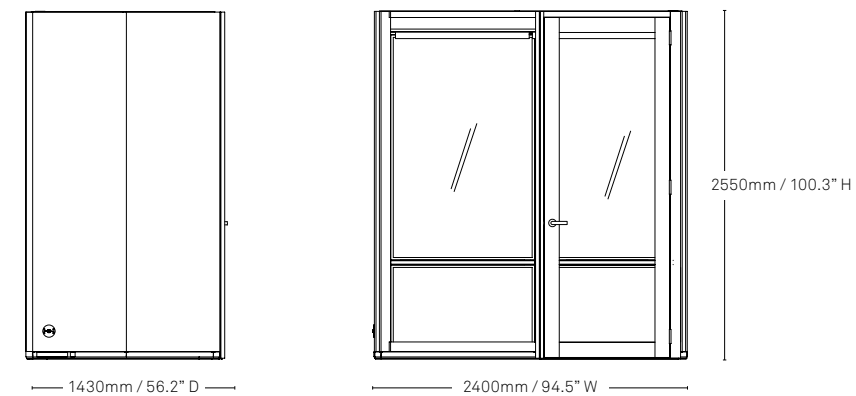

Duo Work Room

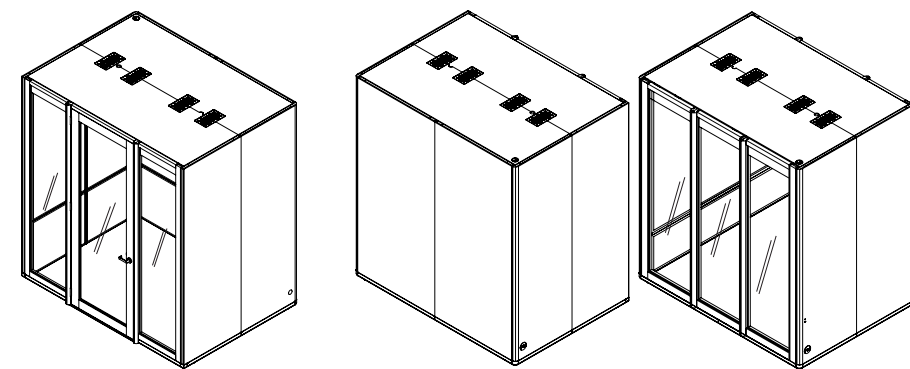

Room back: acoustic panel

Room back: glazed panel

Standard height is:
2550mm

Duo Work Room rear wall available in
2 x solid panels or
3 x glazed panels

Front wall available in central
glass door and 2 x glazed panels.

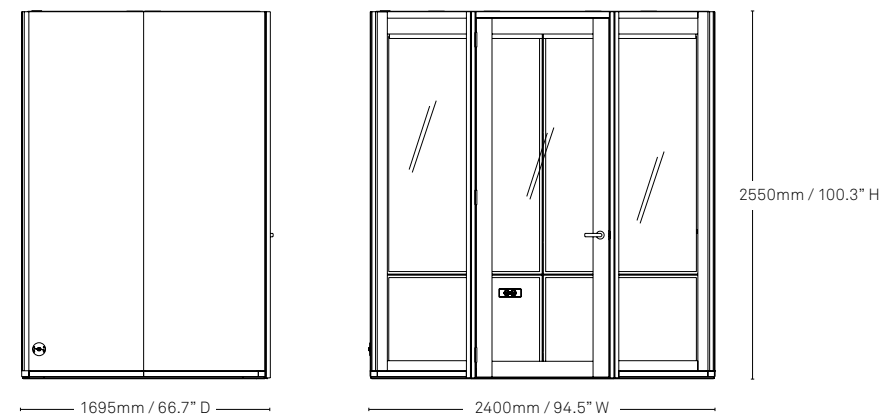

Meeting Room

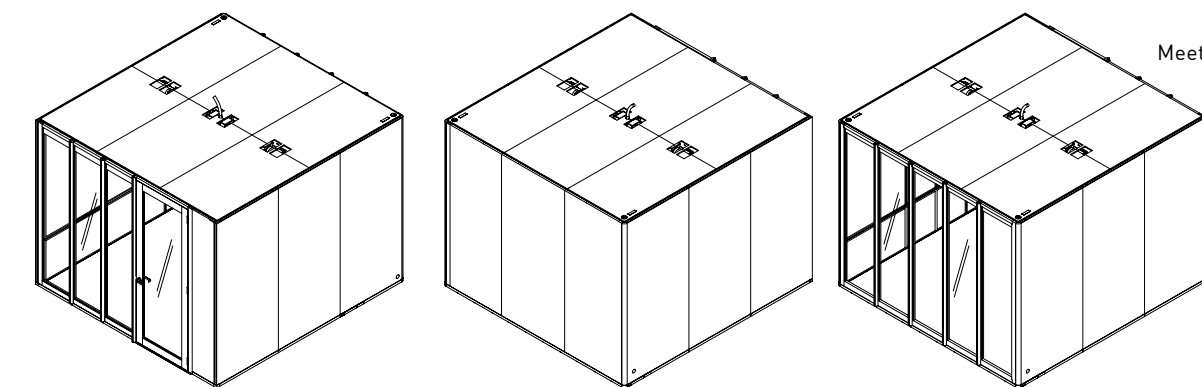

Front: offset door panel

Room back: acoustic panel

Room back: glazed panel

Standard height is:
2550mm

Meeting Room rear wall available in
a solid panel or
5 x glazed panels

Front wall available in
3 x glazed panels.

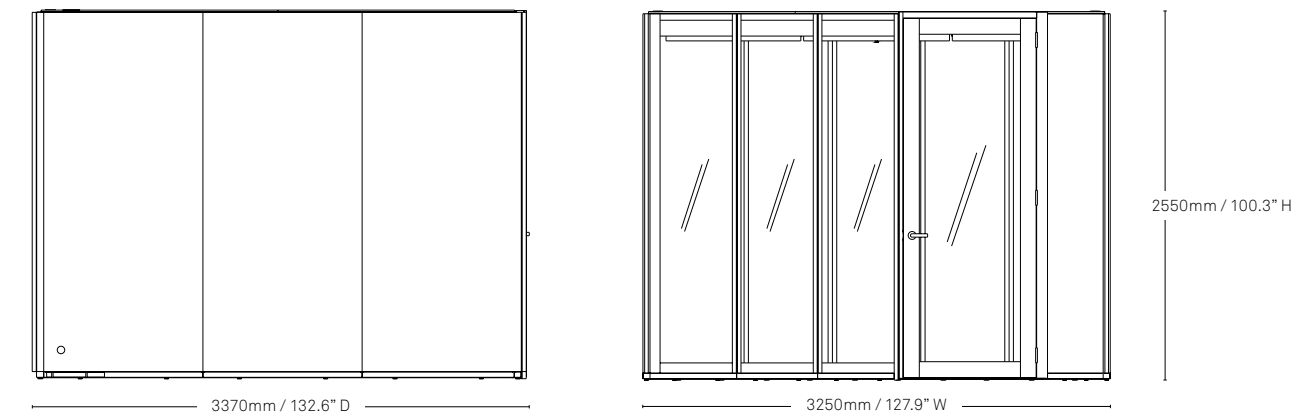

How to Select Finishes

For a full list of our Focus Quiet Room finishes please [click here](#).

1. Exterior Side Walls (solid acoustic panel)

- _ Timber Natural in either Beech or Walnut Milano
- _ Upholstered panels in a variety of fabric options
- _ Laminated Timber in a variety of colours

2. Interior Side Walls (upper & lower tiles)*

- _ Fabric wrapped in a variety of options
- Perforated metal in a range of powder coat colours

**A combination of the above can be specified per upper and lower*

3. Solid Timber Facia (front & back)*

- _ Timber Natural with clear finish in either Beech or Walnut Milano
- _ Timber Washes in a range of colours
- _ Laminated Timber in a variety of colours

**Front only for Phone Room*

4. Door

- _ Timber Natural with clear finish in either Beech or Walnut Milano
- _ Timber Washes in a range of colours

5. Exterior Front/Rear Walls (left or right)*

- _ Glazed panel
- _ Solid acoustic panel
 - Timber Natural in either Beech or Walnut Milano
 - Upholstered panels in a variety of fabric options
 - Laminated Timber in a variety of colours

**Rear only for Phone Room*

6. Ceiling Trim Surround*

- _ Timber Natural with clear finish in either Beech or Walnut Milano
- _ Timber Washes in a range of colours

**Ceiling Trim internal Eco Panel in white or black*

7. Ceiling Panels

- _ Perforated metal in a range of powder coat colours
- _ Fabric wrapped in a variety of options





Ecology and sustainability

Schiavello's most important commitment to sustainability is the company-wide Environmental Management System under ISO 14001. The environmental design principles realised means we design for the environment, focusing on efficient energy use and minimum emissions, longevity and durability, re-use and recycling of our products.

Our principles of ME WE (Materials, Energy, Waste Emissions) give us a simple way to think about how our operations impact the environment.

Printed on an Australian made paper stock that is PEFC Certified and made from elemental chlorine-free bleached pulp sourced from sustainably managed forests and non-controversial sources. It is manufactured by an ISO 14001 certified mill using renewable energy sources.



About Schiavello

Schiavello is a multi-disciplinary company dedicated to developing intelligent, inspiring, ecological and resilient solutions for the office, the home and public spaces.

Schiavello's concepts and products are developed in Australia by applying a design process that brings together the company's core design principles and engineering with the creativity of local and international designers.

The Schiavello head office and world-class manufacturing facilities are integral to our continually developing rich tapestry of knowledge. This knowledge ultimately assists us in informing the right solutions and tools for each organisation's needs and people, allowing us to consistently achieve our philosophy that 'Anything is possible'.

To find a Schiavello showroom or partner in your area, please visit [schiavello.com/furniture](https://www.schiavello.com/furniture)

All intellectual property rights and copyrights are reserved. Nothing contained in this brochure may be reproduced without written permission. Schiavello Group Pty Ltd reserves the right to change any or all details without prior notice. All dimensions stated within this document are nominal and/or approximate only and subject to variation.

1 – Concentration

Noun

the action or power of focusing all of one's attention.

2 – Concentrate

Verb

to focus all of one's attention on an object or activity.



Focus Quiet Room: a refuge for uninterrupted focus and privacy.

www.schiavellofurniture.com/focus-quiet-room